

LM2717-ADJ

Dual Step-Down DC/DC Converter

General Description

The LM2717-ADJ is composed of two PWM DC/DC buck (step-down) converters. Both converters are used to generate an adjustable output voltage as low as 1.267V. Both also feature low $R_{DS(ON)}$ (0.16 Ω) internal switches for maximum efficiency. Operating frequency can be adjusted anywhere between 300kHz and 600kHz allowing the use of small external components. External soft-start pins for each converter enables the user to tailor the soft-start times to a specific application. Each converter may also be shut down independently with its own shutdown pin. The LM2717-ADJ is available in a low profile 24-lead TSSOP package ensuring a low profile overall solution.

Features

- Adjustable buck converter with a 2.2A, 0.16 Ω , internal switch (Buck 1)
- Adjustable buck converter with a 3.2A, 0.16 Ω , internal switch (Buck 2)
- Operating input voltage range of 4V to 20V
- Input undervoltage protection
- 300kHz to 600kHz pin adjustable operating frequency
- Over temperature protection
- Small 24-Lead TSSOP package

Applications

- TFT-LCD Displays
- Handheld Devices
- Portable Applications
- Laptop Computers
- Automotive Applications

Typical Application Circuit

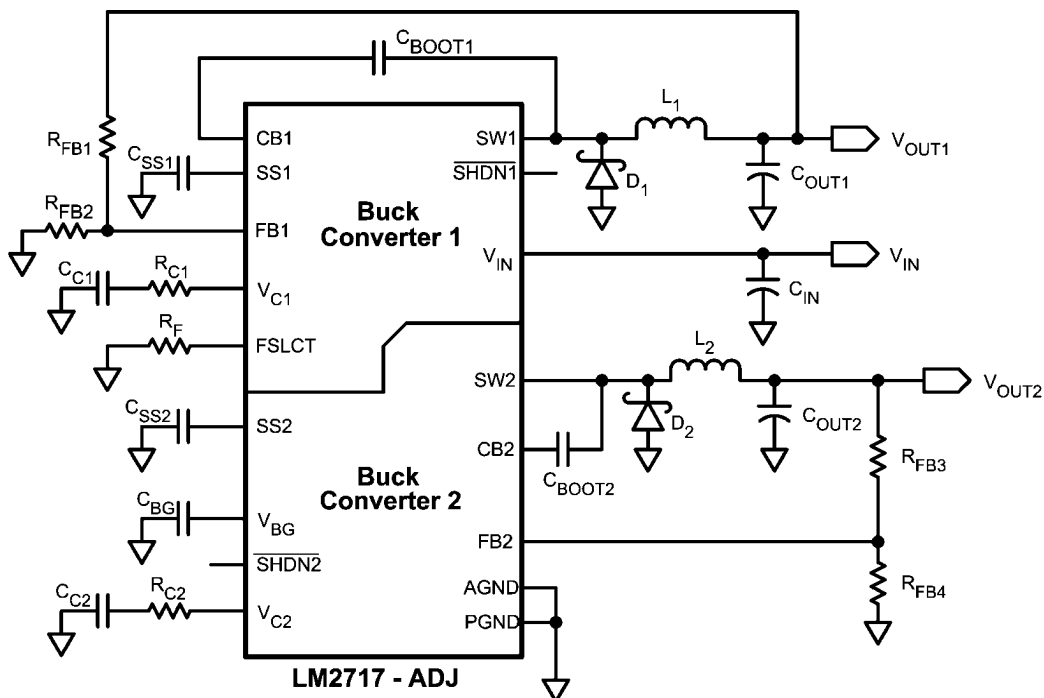

20167901

Connection Diagram

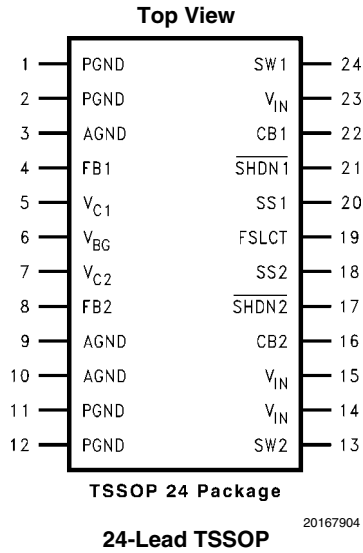

Ordering Information

Order Number	Spec	Package Type	NSC Package Drawing	Supplied As
LM2717MT-ADJ		TSSOP-24	MTC24	61 Units, Rail
LM2717MTX-ADJ		TSSOP-24	MTC24	2500 Units, Tape and Reel
LM2717MT-ADJ	NOPB	TSSOP-24	MTC24	61 Units, Rail
LM2717MTX-ADJ	NOPB	TSSOP-24	MTC24	2500 Units, Tape and Reel

Pin Descriptions

Pin	Name	Function
1	PGND	Power ground. PGND and AGND pins must be connected together directly at the part.
2	PGND	Power ground. PGND and AGND pins must be connected together directly at the part.
3	AGND	Analog ground. PGND and AGND pins must be connected together directly at the part.
4	FB1	Buck 1 output voltage feedback input.
5	V _{C1}	Buck 1 compensation network connection. Connected to the output of the voltage error amplifier.
6	V _{BG}	Bandgap connection.
7	V _{C2}	Buck 2 compensation network connection. Connected to the output of the voltage error amplifier.
8	FB2	Buck 2 output voltage feedback input.
9	AGND	Analog ground. PGND and AGND pins must be connected together directly at the part.
10	AGND	Analog ground. PGND and AGND pins must be connected together directly at the part.
11	PGND	Power ground. PGND and AGND pins must be connected together directly at the part.
12	PGND	Power ground. PGND and AGND pins must be connected together directly at the part.
13	SW2	Buck 2 power switch input. Switch connected between V _{IN} pins and SW2 pin.
14	V _{IN}	Analog power input. All V _{IN} pins are internally connected and should be connected together directly at the part.
15	V _{IN}	Analog power input. All V _{IN} pins are internally connected and should be connected together directly at the part.
16	CB2	Buck 2 converter bootstrap capacitor connection.
17	$\overline{\text{SHDN2}}$	Shutdown pin for Buck 2 converter. Active low.
18	SS2	Buck 2 soft start pin.
19	FSLCT	Switching frequency select input. Use a resistor to set the frequency anywhere between 300kHz and 600kHz.
20	SS1	Buck 1 soft start pin.
21	$\overline{\text{SHDN1}}$	Shutdown pin for Buck 1 converter. Active low.
22	CB1	Buck 1 converter bootstrap capacitor connection.
23	V _{IN}	Analog power input. All V _{IN} pins are internally connected and should be connected together directly at the part.
24	SW1	Buck 1 power switch input. Switch connected between V _{IN} pins and SW1 pin.

Absolute Maximum Ratings (Note 1)

If Military/Aerospace specified devices are required, please contact the National Semiconductor Sales Office/Distributors for availability and specifications.

V_{IN}	-0.3V to 22V
SW1 Voltage	-0.3V to 22V
SW2 Voltage	-0.3V to 22V
FB1, FB2 Voltages	-0.3V to 7V
CB1, CB2 Voltages	-0.3V to $V_{IN}+7V$ ($V_{IN}=V_{SW}$)
V_{C1} Voltage	$1.75V \leq V_{C1} \leq 2.25V$
V_{C2} Voltage	$0.965V \leq V_{C2} \leq 1.565V$
$\overline{SHDN1}$ Voltage	-0.3V to 7.5V
$\overline{SHDN2}$ Voltage	-0.3V to 7.5V
SS1 Voltage	-0.3V to 2.1V
SS2 Voltage	-0.3V to 2.1V
FSLCT Voltage	AGND to 5V

Maximum Junction Temperature	150°C
Power Dissipation (Note 2)	Internally Limited
Lead Temperature	300°C
Vapor Phase (60 sec.)	215°C
Infrared (15 sec.)	220°C
ESD Susceptibility (Note 3)	
Human Body Model	2kV

Operating Conditions

Operating Junction Temperature Range (Note 4)	-40°C to +125°C
Storage Temperature	-65°C to +150°C
Supply Voltage	4V to 20V
SW1 Voltage	20V
SW2 Voltage	20V
Switching Frequency	300kHz to 600kHz

Electrical Characteristics

Specifications in standard type face are for $T_J = 25^\circ\text{C}$ and those with **boldface type** apply over the full **Operating Temperature Range** ($T_J = -40^\circ\text{C}$ to $+125^\circ\text{C}$). $V_{IN} = 5V$, $I_L = 0A$, and $F_{SW} = 300\text{kHz}$ unless otherwise specified.

Symbol	Parameter	Conditions	Min (Note 4)	Typ (Note 5)	Max (Note 4)	Units
I_Q	Total Quiescent Current (both switchers)	Not Switching		2.7	6	mA
		Switching, switch open		6	12	mA
		$V_{\overline{SHDN}} = 0V$		9	27	μA
V_{BG}	Bandgap Voltage		1.248 1.230	1.267	1.294 1.299	V
$\%V_{BG}/\Delta V_{IN}$	Bandgap Voltage Line Regulation		-0.01		0.01 0.125	%/V
V_{FB1}	Buck 1 Feedback Voltage		1.236 1.214	1.258	1.286 1.288	V
V_{FB2}	Buck 2 Feedback Voltage		1.236 1.214	1.258	1.286 1.288	V
I_{CL1} (Note 6)	Buck 1 Switch Current Limit	$V_{IN} = 8V$ (Note 7)		2.2		A
		$V_{IN} = 12V$, $V_{OUT} = 3.3V$	1.4	1.65	2.0	
I_{CL2} (Note 6)	Buck 2 Switch Current Limit	$V_{IN} = 8V$ (Note 7)		3.2		A
		$V_{IN} = 12V$, $V_{OUT} = 5V$	2.6	3.05	3.5	
I_{B1}	Buck 1 FB Pin Bias Current (Note 8)	$V_{IN} = 20V$		70	400	nA
I_{B2}	Buck 2 FB Pin Bias Current (Note 8)	$V_{IN} = 20V$		65	400	nA
V_{IN}	Input Voltage Range		4		20	V
g_{m1}	Buck 1 Error Amp Transconductance	$\Delta I = 20\mu\text{A}$		1340		μmho
g_{m2}	Buck 2 Error Amp Transconductance	$\Delta I = 20\mu\text{A}$		1360		μmho
A_{V1}	Buck 1 Error Amp Voltage Gain			134		V/V
A_{V2}	Buck 2 Error Amp Voltage Gain			136		V/V
D_{MAX}	Maximum Duty Cycle		89	93		%
F_{SW}	Switching Frequency	$R_F = 46.4k$	240	300	360	kHz
		$R_F = 22.6k$	480	600	720	kHz

Symbol	Parameter	Conditions	Min (Note 4)	Typ (Note 5)	Max (Note 4)	Units
$I_{\overline{\text{SHDN1}}}$	Buck 1 Shutdown Pin Current	$0V < V_{\overline{\text{SHDN1}}} < 7.5V$	-5		5	μA
$I_{\overline{\text{SHDN2}}}$	Buck 2 Shutdown Pin Current	$0V < V_{\overline{\text{SHDN2}}} < 7.5V$	-5		5	μA
I_{L1}	Buck 1 Switch Leakage Current	$V_{IN} = 20V$		0.01	5	μA
I_{L2}	Buck 2 Switch Leakage Current	$V_{IN} = 20V$		0.01	5	μA
R_{DSON1}	Buck 1 Switch R_{DSON} (Note 9)	$I_{\text{SW}} = 100\text{mA}$		160	180 300	$\text{m}\Omega$
R_{DSON2}	Buck 2 Switch R_{DSON} (Note 9)	$I_{\text{SW}} = 100\text{mA}$		160	180 300	$\text{m}\Omega$
$\text{Th}_{\overline{\text{SHDN1}}}$	Buck 1 $\overline{\text{SHDN}}$ Threshold	Output High	1.8	1.36		V
		Output Low		1.33	0.7	
$\text{Th}_{\overline{\text{SHDN2}}}$	Buck 2 $\overline{\text{SHDN}}$ Threshold	Output High	1.8	1.36		V
		Output Low		1.33	0.7	
I_{SS1}	Buck 1 Soft Start Pin Current		4	9	15	μA
I_{SS2}	Buck 2 Soft Start Pin Current		4	9	15	μA
UVP	On Threshold		4	3.8		V
	Off Threshold			3.6	3.3	
θ_{JA}	Thermal Resistance (Note 10)	TSSOP, package only		115		$^{\circ}\text{C}/\text{W}$

Note 1: Absolute maximum ratings are limits beyond which damage to the device may occur. Operating Ratings are conditions for which the device is intended to be functional, but device parameter specifications may not be guaranteed. For guaranteed specifications and test conditions, see the Electrical Characteristics.

Note 2: The maximum allowable power dissipation is a function of the maximum junction temperature, $T_{\text{J(MAX)}}$, the junction-to-ambient thermal resistance, θ_{JA} , and the ambient temperature, T_{A} . See the Electrical Characteristics table for the thermal resistance. The maximum allowable power dissipation at any ambient temperature is calculated using: $P_{\text{D}}(\text{MAX}) = (T_{\text{J(MAX)}} - T_{\text{A}})/\theta_{\text{JA}}$. Exceeding the maximum allowable power dissipation will cause excessive die temperature, and the regulator will go into thermal shutdown.

Note 3: The human body model is a 100 pF capacitor discharged through a 1.5k Ω resistor into each pin.

Note 4: All limits guaranteed at room temperature (standard typeface) and at temperature extremes (bold typeface). All room temperature limits are 100% tested or guaranteed through statistical analysis. All limits at temperature extremes are guaranteed via correlation using standard Statistical Quality Control (SQC) methods. All limits are used to calculate Average Outgoing Quality Level (AOQL).

Note 5: Typical numbers are at 25 $^{\circ}\text{C}$ and represent the most likely norm.

Note 6: Duty cycle affects current limit due to ramp generator.

Note 7: Current limit at 0% duty cycle. See *TYPICAL PERFORMANCE* section for Switch Current Limit vs. Input Voltage.

Note 8: Bias current flows into FB pin.

Note 9: Includes the bond wires and package leads, R_{DSON} from V_{IN} pin(s) to SW pin.

Note 10: Refer to National's packaging website for more detailed thermal information and mounting techniques for the TSSOP package.

Typical Performance Characteristics

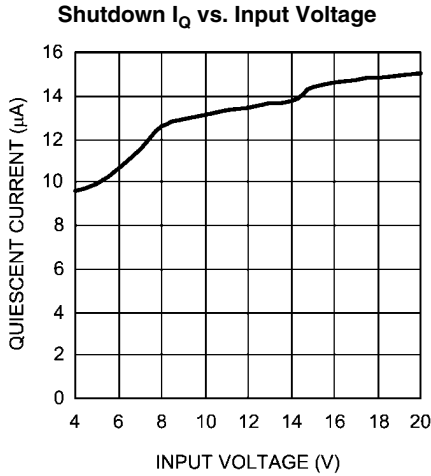

20167960

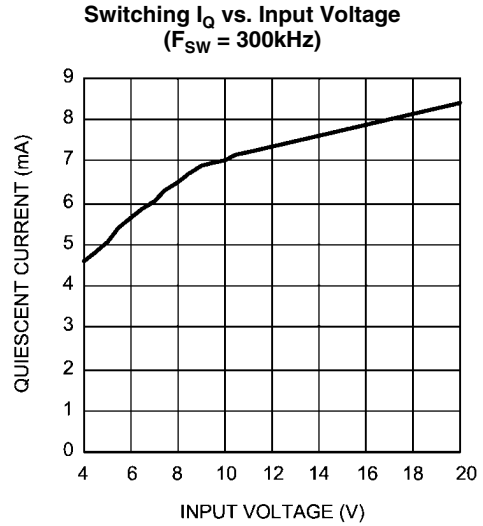

20167961

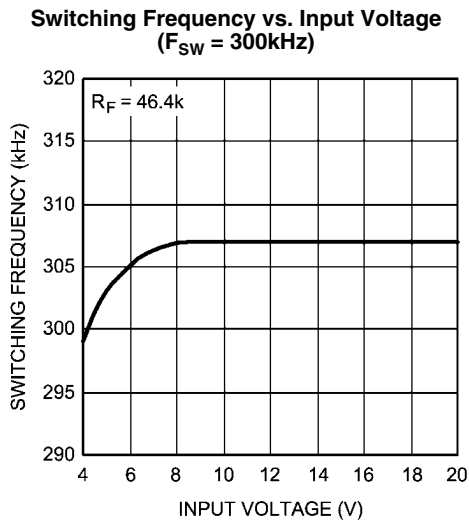

20167962

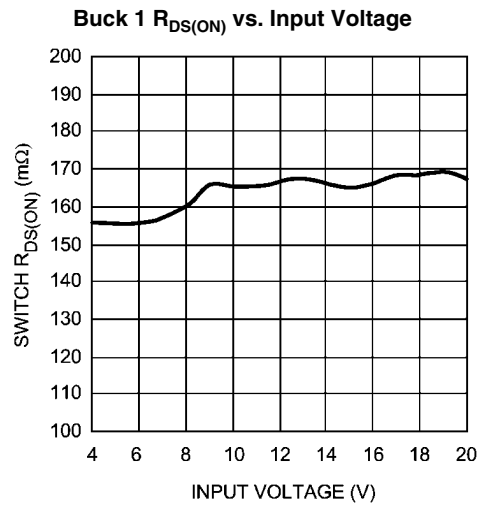

20167963

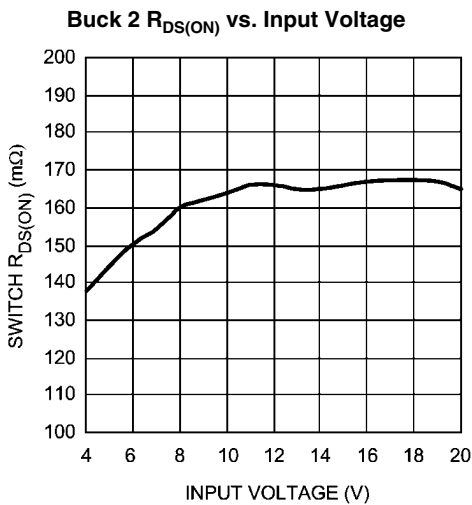

20167964

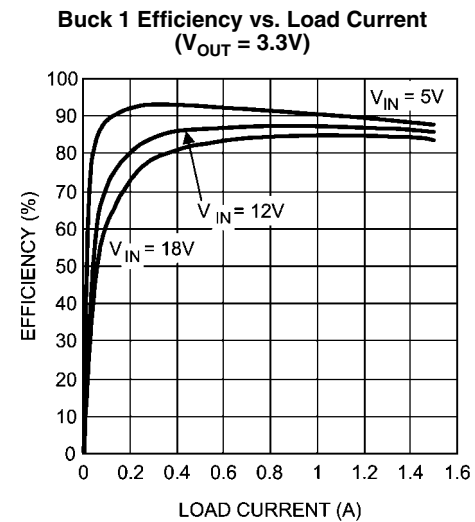

20167965

Buck 2 Efficiency vs. Load Current
($V_{OUT} = 15V$)

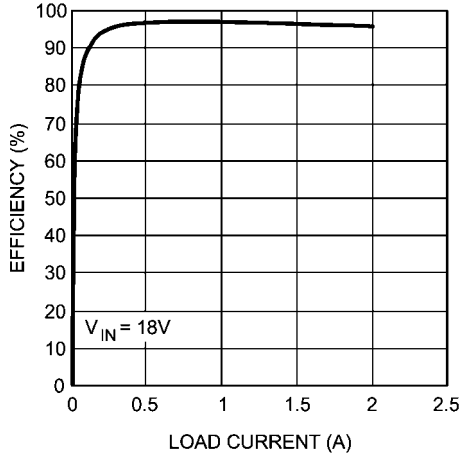

20167966

Buck 2 Efficiency vs. Load Current
($V_{OUT} = 5V$)

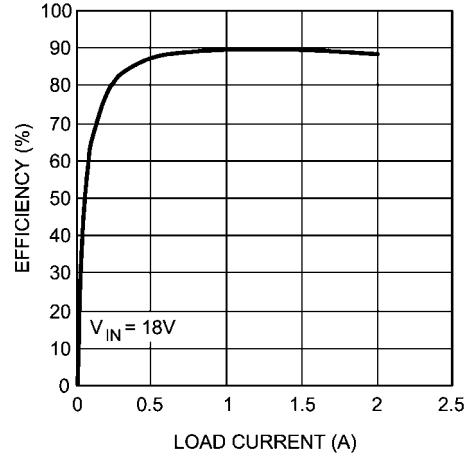

20167967

Buck 1 Switch Current Limit vs. Input Voltage

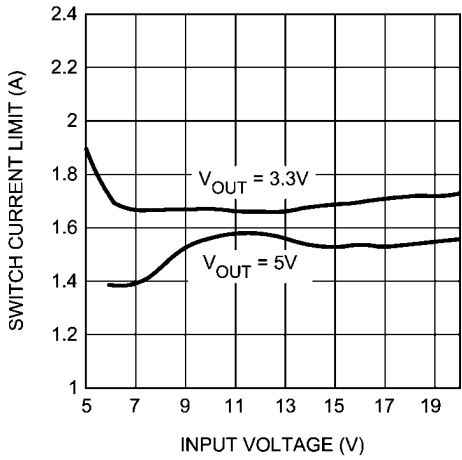

20167968

Buck 2 Switch Current Limit vs. Input Voltage

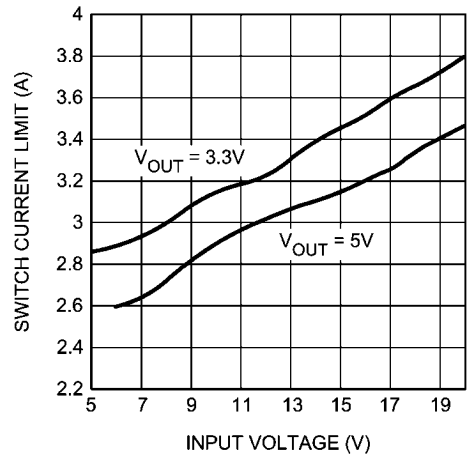

20167969

Buck 1 Switch Current Limit vs. Temperature
($V_{IN} = 12V$)

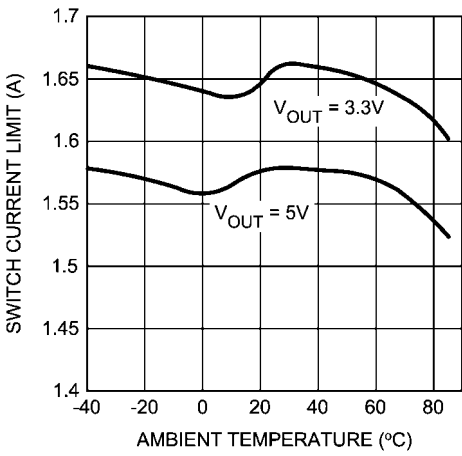

20167912

Buck 2 Switch Current Limit vs. Temperature
($V_{IN} = 12V$)

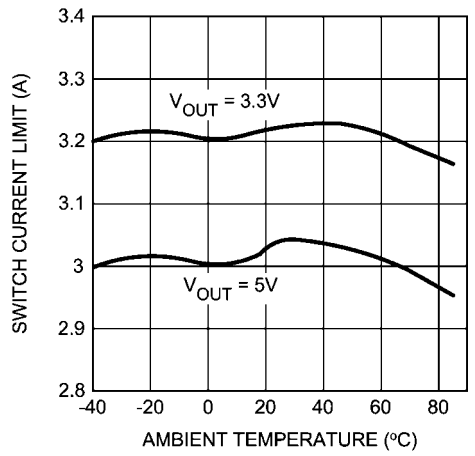

20167913

Buck 1 Switch ON Resistance vs. Temperature

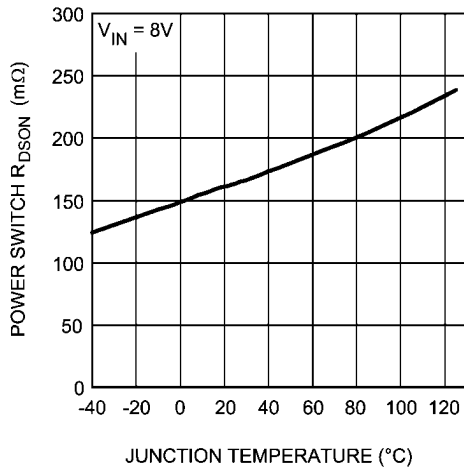

20167910

Buck 2 Switch ON Resistance vs. Temperature

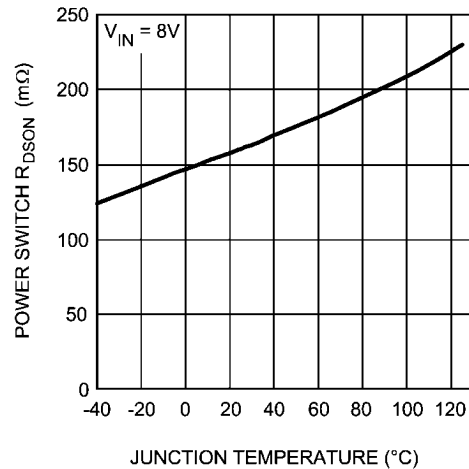

20167911

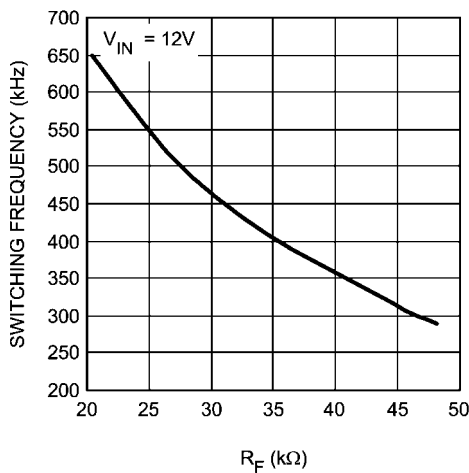
Switching Frequency vs. R_F Resistance

20167914

Buck Operation

PROTECTION (BOTH REGULATORS)

The LM2717-ADJ has dedicated protection circuitry running during normal operation to protect the IC. The Thermal Shutdown circuitry turns off the power devices when the die temperature reaches excessive levels. The UVP comparator protects the power devices during supply power startup and shutdown to prevent operation at voltages less than the minimum input voltage. The OVP comparator is used to prevent the output voltage from rising at no loads allowing full PWM operation over all load conditions. The LM2717-ADJ also features a shutdown mode for each converter decreasing the supply current to approximately 10μA (both in shutdown mode).

CONTINUOUS CONDUCTION MODE

The LM2717-ADJ contains current-mode, PWM buck regulators. A buck regulator steps the input voltage down to a lower output voltage. In continuous conduction mode (when the inductor current never reaches zero at steady state), the buck regulator operates in two cycles. The power switch is connected between V_{IN} and SW1 and SW2.

In the first cycle of operation the transistor is closed and the diode is reverse biased. Energy is collected in the inductor

and the load current is supplied by C_{OUT} and the rising current through the inductor.

During the second cycle the transistor is open and the diode is forward biased due to the fact that the inductor current cannot instantaneously change direction. The energy stored in the inductor is transferred to the load and output capacitor.

The ratio of these two cycles determines the output voltage. The output voltage is defined approximately as:

$$D = \frac{V_{OUT}}{V_{IN}}, D' = (1-D)$$

where D is the duty cycle of the switch, D and D' will be required for design calculations.

The LM2717-ADJ has a minimum switch ON time which corresponds to a minimum duty cycle of approximately 10% at 600kHz operation and approximately 5% at 300kHz operation. In the case of some high voltage differential applications (low duty cycle operation) this minimum duty cycle may be exceeded causing the feedback pin over-voltage protection to trip as the output voltage rises. This will put the device into a PFM type operation which can cause an unpredictable frequency spectrum and may cause the average output voltage to rise slightly. If this is a concern the switching frequency may

be lowered and/or a pre-load added to the output to keep the device full PWM operation. Note that the OVP function monitors the FB pin so it will not function if the feedback resistor is disconnected from the output. Due to slight differences between the two converters it is recommended that Buck 1 be used for the lower of the two output voltages for best operation.

DESIGN PROCEDURE

This section presents guidelines for selecting external components.

SETTING THE OUTPUT VOLTAGE

The output voltage is set using the feedback pin and a resistor divider connected to the output as shown in *Figure 4*. The feedback pin voltage (V_{FB}) is 1.258V, so the ratio of the feedback resistors sets the output voltage according to the following equation:

$$R_{FB1(3)} = R_{FB2(4)} \times \frac{V_{OUT} - V_{FB1(2)}}{V_{FB1(2)}} \Omega$$

INPUT CAPACITOR

A low ESR aluminum, tantalum, or ceramic capacitor is needed between the input pin and power ground. This capacitor prevents large voltage transients from appearing at the input. The capacitor is selected based on the RMS current and voltage requirements. The RMS current is given by:

$$I_{RMS} = I_{OUT} \times \frac{\sqrt{V_{OUT}(V_{IN} - V_{OUT})}}{V_{IN}}$$

The RMS current reaches its maximum ($I_{OUT}/2$) when V_{IN} equals $2V_{OUT}$. This value should be calculated for both regulators and added to give a total RMS current rating. For an aluminum or ceramic capacitor, the voltage rating should be at least 25% higher than the maximum input voltage. If a tantalum capacitor is used, the voltage rating required is about twice the maximum input voltage. The tantalum capacitor should be surge current tested by the manufacturer to prevent being shorted by the inrush current. The minimum capacitor value should be 47 μ F for lower output load current applications and less dynamic (quickly changing) load conditions. For higher output current applications or dynamic load conditions a 68 μ F to 100 μ F low ESR capacitor is recommended. It is also recommended to put a small ceramic capacitor (0.1 μ F to 4.7 μ F) between the input pins and ground to reduce high frequency spikes.

INDUCTOR SELECTION

The most critical parameter for the inductor in a current mode switcher is the minimum value required for stable operation. To prevent subharmonic oscillations and achieve good phase margin a target minimum value for the inductor is:

$$L_{MIN} = \frac{(D-0.5+2/\pi)(V_{IN}-V_{OUT})R_{DSON}}{(1-D)(0.164 * F_{SW})} \text{ (H)}$$

Where V_{IN} is the minimum input voltage and R_{DSON} is the maximum switch ON resistance. For best stability the inductor should be in the range of $0.5L_{MIN}$ (absolute minimum) and $2L_{MIN}$. Using an inductor with a value less than $0.5L_{MIN}$ can cause subharmonic oscillations. The inductor should meet

this minimum requirement at the peak inductor current expected for the application regardless of what the inductor ripple current and output ripple voltage requirements are. A value larger than $2L_{MIN}$ is acceptable if the ripple requirements of the application require it but it may reduce the phase margin and increase the difficulty in compensating the circuit. The most important parameters for the inductor from an applications standpoint are the inductance, peak current and the DC resistance. The inductance is related to the peak-to-peak inductor ripple current, the input and the output voltages (for 300kHz operation):

$$L = \frac{(V_{IN} - V_{OUT})V_{OUT}}{V_{IN} \times I_{RIPPLE} \times 300 \text{ kHz}}$$

A higher value of ripple current reduces inductance, but increases the conduction loss, core loss, and current stress for the inductor and switch devices. It also requires a bigger output capacitor for the same output voltage ripple requirement. A reasonable value is setting the ripple current to be 30% of the DC output current. Since the ripple current increases with the input voltage, the maximum input voltage is always used to determine the inductance. The DC resistance of the inductor is a key parameter for the efficiency. Lower DC resistance is available with a bigger winding area. A good tradeoff between the efficiency and the core size is letting the inductor copper loss equal 2% of the output power.

OUTPUT CAPACITOR

The selection of C_{OUT} is driven by the maximum allowable output voltage ripple. The output ripple in the constant frequency, PWM mode is approximated by:

$$V_{RIPPLE} = I_{RIPPLE} \left(ESR + \frac{1}{8F_{S}C_{OUT}} \right)$$

The ESR term usually plays the dominant role in determining the voltage ripple. Low ESR ceramic, aluminum electrolytic, or tantalum capacitors (such as MuRata MLCC, Taiyo Yuden MLCC, Nichicon PL series, Sanyo OS-CON, Sprague 593D, 594D, AVX TPS, and CDE polymer aluminum) is recommended. An aluminum electrolytic capacitor is not recommended for temperatures below -25°C since its ESR rises dramatically at cold temperatures. Ceramic or tantalum capacitors have much better ESR specifications at cold temperature and is preferred for low temperature applications.

BOOTSTRAP CAPACITOR

A 4.7nF ceramic capacitor or larger is recommended for the bootstrap capacitor. For applications where the input voltage is less than twice the output voltage a larger capacitor is recommended, generally 0.1 μ F to 1 μ F to ensure plenty of gate drive for the internal switches and a consistently low R_{DSON} .

SOFT-START CAPACITOR (BOTH REGULATORS)

The LM2717-ADJ contains circuitry that can be used to limit the inrush current on start-up of the DC/DC switching regulators. This inrush current limiting circuitry serves as a soft-start. The external SS pins are used to tailor the soft-start for a specific application. A current (I_{SS}) charges the external soft-start capacitor, C_{SS} . The soft-start time can be estimated as:

$$T_{SS} = C_{SS} * 0.6V/I_{SS}$$

When programming the soft-start time use the equation given in the *Soft-Start Capacitor* section above. The soft-start function is used simply to limit inrush current to the device that

could stress the input voltage supply. The soft-start time described above is the time it takes for the current limit to ramp to maximum value. When this function is used the current limit starts at a low value and increases to nominal at the set soft-start time. Under maximum load conditions the output voltage may rise at the same rate as the soft-start, however at light or no load conditions the output voltage will rise much faster as the switch will not need to conduct much current to charge the output capacitor.

SHUTDOWN OPERATION (BOTH REGULATORS)

The shutdown pins of the LM2717-ADJ are designed so that they may be controlled using 1.8V or higher logic signals. If the shutdown function is not to be used the pin may be left open. The maximum voltage to the shutdown pin should not exceed 7.5V. If the use of a higher voltage is desired due to system or other constraints it may be used, however a 100k or larger resistor is recommended between the applied voltage and the shutdown pin to protect the device.

SCHOTTKY DIODE

The breakdown voltage rating of D_1 and D_2 is preferred to be 25% higher than the maximum input voltage. The current rating for the diode should be equal to the maximum output current for best reliability in most applications. In cases where the input voltage is much greater than the output voltage the average diode current is lower. In this case it is possible to use a diode with a lower average current rating, approximately $(1-D) \cdot I_{OUT}$ however the peak current rating should be higher than the maximum load current.

LOOP COMPENSATION

The general purpose of loop compensation is to meet static and dynamic performance requirements while maintaining stability. Loop gain is what is usually checked to determine small-signal performance. Loop gain is equal to the product of control-output transfer function and the output-control transfer function (the compensation network transfer function). The DC loop gain of the LM2717 is usually around 55dB to 60dB when loaded. Generally speaking it is a good idea to have a loop gain slope that is -20dB/decade from a very low frequency to well beyond the crossover frequency. The crossover frequency should not exceed one-fifth of the switching frequency, i.e. 60kHz in the case of 300kHz switching frequency. The higher the bandwidth is, the faster the load transient response speed will potentially be. However, if the duty cycle saturates during a load transient, further increasing the small signal bandwidth will not help. Since the control-output transfer function usually has very limited low frequency gain, it is a good idea to place a pole in the compensation at zero frequency, so that the low frequency gain will be relatively large. A large DC gain means high DC regulation accuracy (i.e. DC voltage changes little with load or line variations). The rest of the compensation scheme depends highly on the shape of the control-output plot.

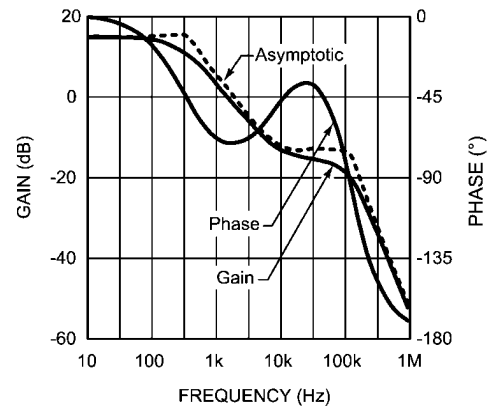

20167916

FIGURE 1. Control-Output Transfer Function

As shown in *Figure 1*, the example control-output transfer function consists of one pole (f_p), one zero (f_z), and a double pole at f_n (half the switching frequency). The following can be done to create a -20dB/decade roll-off of the loop gain: Place the first pole at 0Hz, the first zero at f_p , the second pole at f_z , and the second zero at f_n . The resulting output-control transfer function is shown in *Figure 2*.

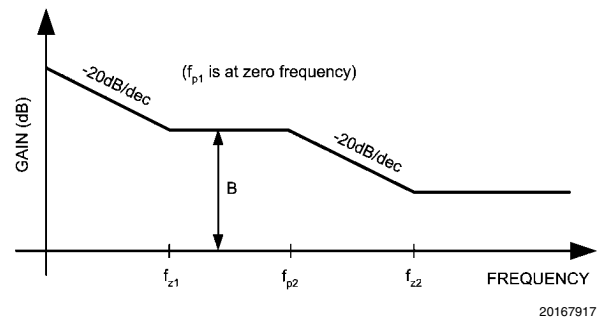

20167917

FIGURE 2. Output-Control Transfer Function

The control-output corner frequencies, and thus the desired compensation corner frequencies, can be determined approximately by the following equations:

$$f_z = \frac{1}{2\pi R_e C_o}$$

$$f_p = \frac{1}{2\pi R_o C_o} + \frac{.5}{2\pi L f C_o}$$

Where C_o is the output capacitance, R_e is the output capacitance ESR, R_o is the load resistance, L is the inductor value, and f is the switching frequency used.

Since f_p is determined by the output network, it will shift with loading (R_o) and duty cycle. First determine the range of frequencies (f_{pmin}/f_{pmax}) of the pole across the expected load range, then place the first compensation zero within that range.

Example: $V_o = 5V$, $R_e = 20m\Omega$, $C_o = 100\mu F$, $R_{o\max} = 5V/100mA = 50\Omega$, $R_{o\min} = 5V/1A = 5\Omega$, $L = 10\mu H$, $f = 300kHz$:

$$f_z = \frac{1}{2\pi \cdot 20 \text{ m}\Omega \cdot 100 \text{ }\mu\text{F}} = 80 \text{ kHz}$$

$$f_{p \text{ min}} = \frac{1}{2\pi \cdot 50\Omega \cdot 100 \text{ }\mu\text{F}} + \frac{0.5}{2\pi \cdot 300\text{k} \cdot 10\mu \cdot 100 \text{ }\mu\text{F}} = 297 \text{ Hz}$$

$$f_{p \text{ max}} = \frac{1}{2\pi \cdot 5\Omega \cdot 100 \text{ }\mu\text{F}} + \frac{0.5}{2\pi \cdot 300\text{k} \cdot 10\mu \cdot 100 \text{ }\mu\text{F}} = 584 \text{ Hz}$$

Once the fp range is determined, R_{c1} should be calculated using:

$$R_{c1} = \frac{B}{g_m} \left(\frac{R_1 + R_2}{R_1} \right)$$

Where B is the desired gain in V/V at fp (f_{z1}), g_m is the transconductance of the error amplifier, and R1 and R2 are the feedback resistors as shown in *Figure 3*. A gain value around 10dB (3.3v/v) is generally a good starting point.

Example: B = 3.3 v/v, $g_m=1350\mu\text{mho}$, R1 = 20 K Ω , R2 = 59 K Ω :

$$R_{c1} = \frac{3.3}{1350\mu} \cdot \frac{20\text{k} + 59\text{k}}{20\text{k}} \approx 9.76\text{k}$$

Bandwidth will vary proportional to the value of R_{c1} . Next, C_{c1} can be determined with the following equation:

$$C_{c1} = \frac{1}{2\pi \cdot f_p \cdot R_{c1}}$$

Example: $f_{p \text{ min}} = 297 \text{ Hz}$, $R_{c1} = 20 \text{ K}\Omega$:

$$C_{c1} = \frac{1}{2\pi \cdot 297 \text{ Hz} \cdot 9.76\text{k}} \approx 56 \text{ nF}$$

The value of C_{c1} should be within the range determined by $f_{p \text{ min}}/f_{p \text{ max}}$. A higher value will generally provide a more stable loop, but too high a value will slow the transient response time. The compensation network (*Figure 3*) will also introduce a low frequency pole which will be close to 0Hz.

A second pole should also be placed at f_z . This pole can be created with a single capacitor C_{c2} and a shorted R_{c2} (see *Figure 3*). The minimum value for this capacitor can be calculated by:

$$C_{c2 \text{ min}} = \frac{1}{2\pi \cdot f_z \cdot R_{c1}}$$

C_{c2} may not be necessary, however it does create a more stable control loop. This is especially important with high load currents.

Example: $f_z = 80 \text{ kHz}$, $R_{c1} = 20 \text{ K}\Omega$:

$$C_{c2 \text{ min}} = \frac{1}{2\pi \cdot 80 \text{ kHz} \cdot 20 \text{ k}\Omega} \cong 100 \text{ pF}$$

A second zero can also be added with a resistor in series with C_{c2} . If used, this zero should be placed at f_n , where the control to output gain rolls off at -40dB/dec. Generally, f_n will be well below the 0dB level and thus will have little effect on stability. R_{c2} can be calculated with the following equation:

$$R_{c2} = \frac{1}{2\pi \cdot f_n \cdot C_{c2}}$$

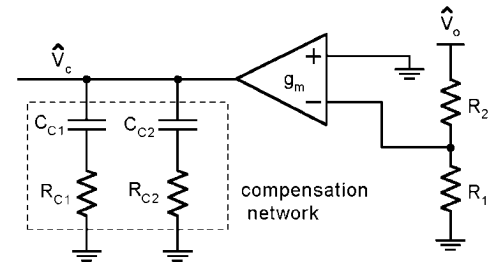

20167930

FIGURE 3. Compensation Network

Note that the values calculated here give a good baseline for stability and will work well with most applications. The values in some cases may need to be adjusted some for optimum stability or the values may need to be adjusted depending on a particular applications bandwidth requirements.

LAYOUT CONSIDERATIONS

The LM2717-ADJ uses two separate ground connections, PGND for the drivers and boost NMOS power device and AGND for the sensitive analog control circuitry. The AGND and PGND pins should be tied directly together at the package. The feedback and compensation networks should be connected directly to a dedicated analog ground plane and this ground plane must connect to the AGND pin. If no analog ground plane is available then the ground connections of the feedback and compensation networks must tie directly to the AGND pin. Connecting these networks to the PGND can inject noise into the system and effect performance.

The input bypass capacitor C_{IN} , as shown in *Figure 4*, must be placed close to the IC. This will reduce copper trace resistance which effects input voltage ripple of the IC. For additional input voltage filtering, a 0.1 μF to 4.7 μF bypass capacitors can be placed in parallel with C_{IN} , close to the V_{IN} pins to shunt any high frequency noise to ground. The output capacitors, C_{OUT1} and C_{OUT2} , should also be placed close to the IC. Any copper trace connections for the C_{OUTX} capacitors can increase the series resistance, which directly effects output voltage ripple. The feedback network, resistors $R_{FB1(3)}$ and $R_{FB2(4)}$, should be kept close to the FB pin, and away from the inductor to minimize copper trace connections that can inject noise into the system. Trace connections made to the inductors and schottky diodes should be minimized to reduce power dissipation and increase overall efficiency. For more detail on switching power supply layout considerations see Application Note AN-1149: *Layout Guidelines for Switching Power Supplies*.

Application Information

Some Recommended Inductors (Others May Be Used)

Manufacturer	Inductor	Contact Information
Coilcraft	DO3316 and DT3316 series	www.coilcraft.com 800-3222645
TDK	SLF10145 series	www.component.tdk.com 847-803-6100
Pulse	P0751 and P0762 series	www.pulseeng.com
Sumida	CDRH8D28 and CDRH8D43 series	www.sumida.com

Some Recommended Input And Output Capacitors (Others May Be Used)

Manufacturer	Capacitor	Contact Information
Vishay Sprague	293D, 592D, and 595D series tantalum	www.vishay.com
Taiyo Yuden	High capacitance MLCC ceramic	www.t-yuden.com
Cornell Dubilier	ESRD series Polymer Aluminum Electrolytic SPV and AFK series V-chip series	www.cde.com
MuRata	High capacitance MLCC ceramic	www.murata.com

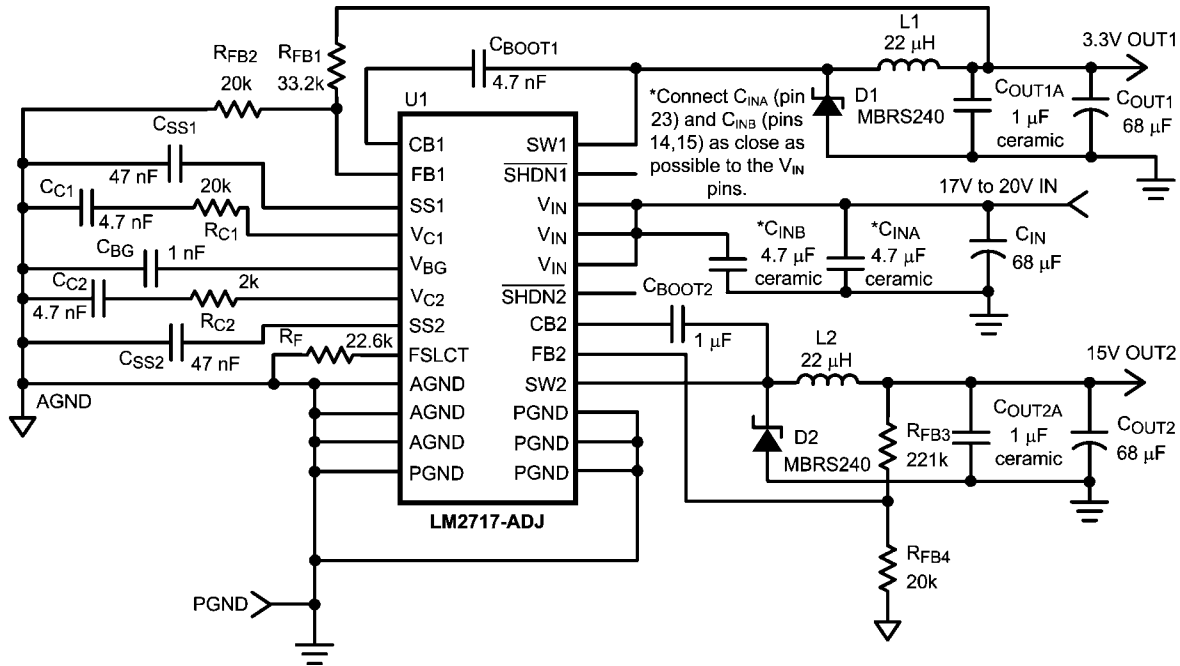

20167958

FIGURE 4. 15V, 3.3V Output Application

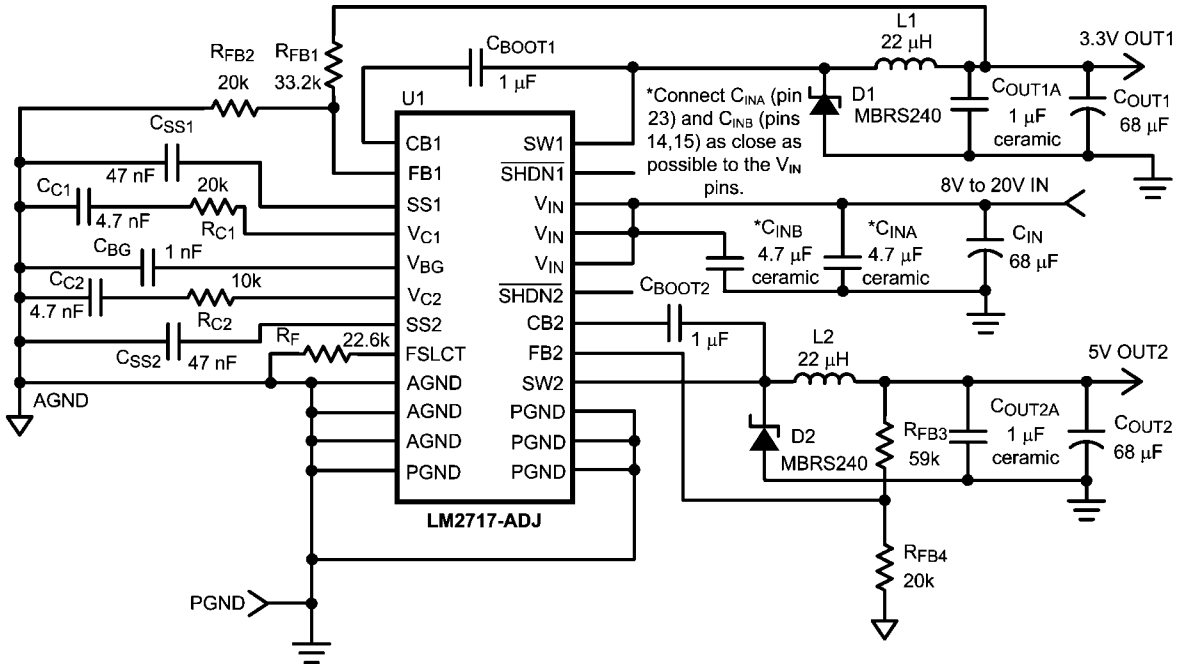

20167959

FIGURE 5. 5V, 3.3V Output Application

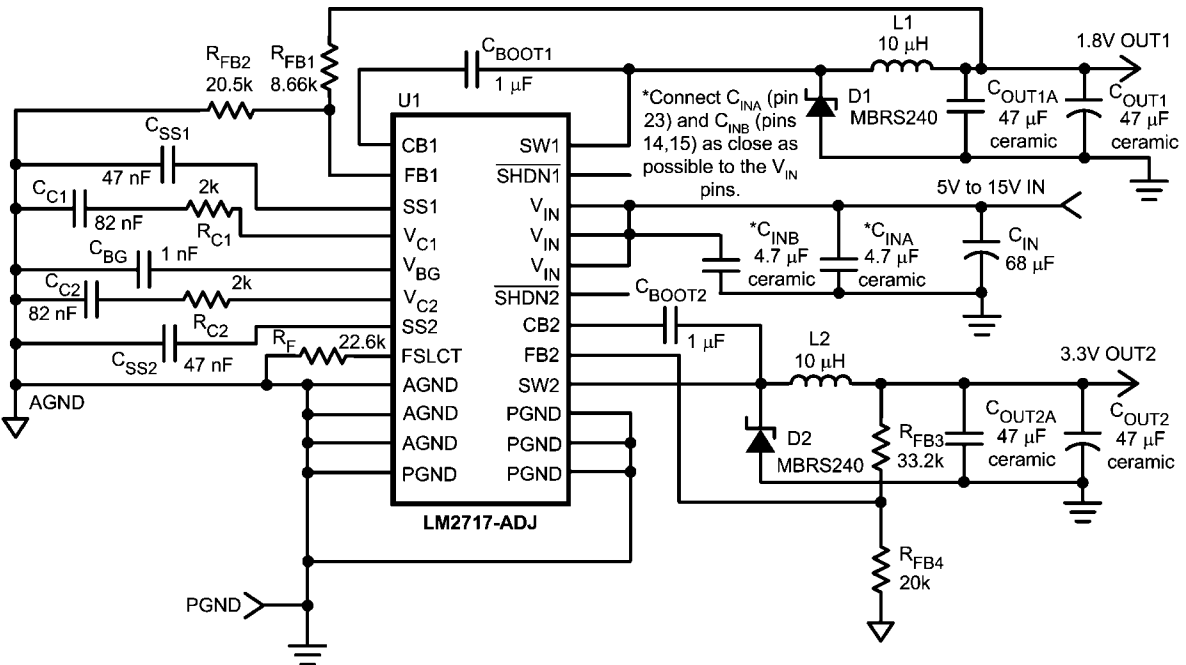

20167915

FIGURE 6. 3.3V, 1.8V Output Application

Physical Dimensions inches (millimeters) unless otherwise noted

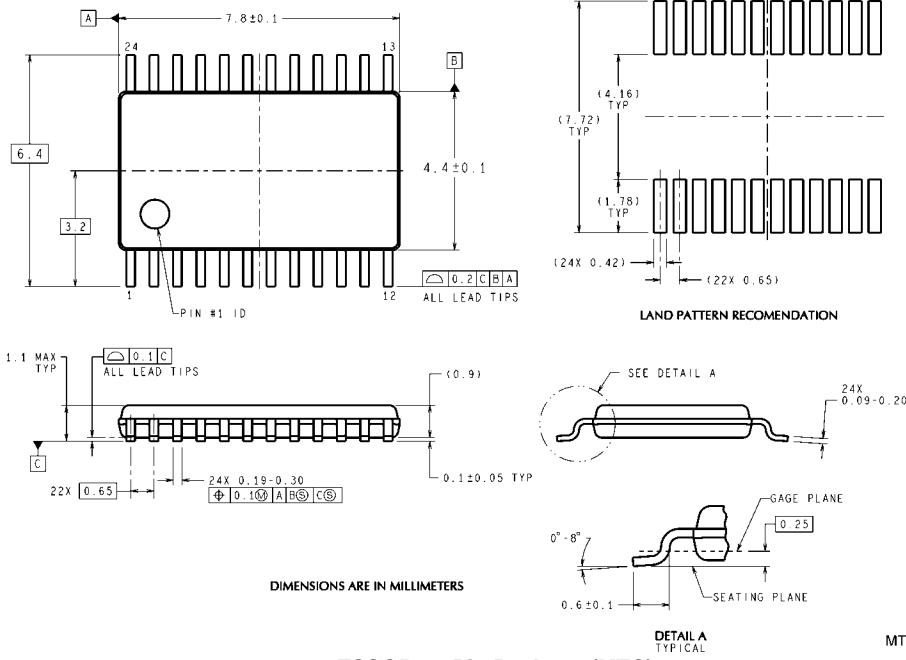

TSSOP-24 Pin Package (MTC)
For Ordering, Refer to Ordering Information Table
NS Package Number MTC24

MTC24 (Rev E)

Notes

For more National Semiconductor product information and proven design tools, visit the following Web sites at:

Products		Design Support	
Amplifiers	www.national.com/amplifiers	WEBENCH	www.national.com/webench
Audio	www.national.com/audio	Analog University	www.national.com/AU
Clock Conditioners	www.national.com/timing	App Notes	www.national.com/appnotes
Data Converters	www.national.com/adc	Distributors	www.national.com/contacts
Displays	www.national.com/displays	Green Compliance	www.national.com/quality/green
Ethernet	www.national.com/ethernet	Packaging	www.national.com/packaging
Interface	www.national.com/interface	Quality and Reliability	www.national.com/quality
LVDS	www.national.com/lvds	Reference Designs	www.national.com/refdesigns
Power Management	www.national.com/power	Feedback	www.national.com/feedback
Switching Regulators	www.national.com/switchers		
LDOs	www.national.com/lido		
LED Lighting	www.national.com/led		
PowerWise	www.national.com/powerwise		
Serial Digital Interface (SDI)	www.national.com/sdi		
Temperature Sensors	www.national.com/tempsensors		
Wireless (PLL/VCO)	www.national.com/wireless		

THE CONTENTS OF THIS DOCUMENT ARE PROVIDED IN CONNECTION WITH NATIONAL SEMICONDUCTOR CORPORATION ("NATIONAL") PRODUCTS. NATIONAL MAKES NO REPRESENTATIONS OR WARRANTIES WITH RESPECT TO THE ACCURACY OR COMPLETENESS OF THE CONTENTS OF THIS PUBLICATION AND RESERVES THE RIGHT TO MAKE CHANGES TO SPECIFICATIONS AND PRODUCT DESCRIPTIONS AT ANY TIME WITHOUT NOTICE. NO LICENSE, WHETHER EXPRESS, IMPLIED, ARISING BY ESTOPPEL OR OTHERWISE, TO ANY INTELLECTUAL PROPERTY RIGHTS IS GRANTED BY THIS DOCUMENT.

TESTING AND OTHER QUALITY CONTROLS ARE USED TO THE EXTENT NATIONAL DEEMS NECESSARY TO SUPPORT NATIONAL'S PRODUCT WARRANTY. EXCEPT WHERE MANDATED BY GOVERNMENT REQUIREMENTS, TESTING OF ALL PARAMETERS OF EACH PRODUCT IS NOT NECESSARILY PERFORMED. NATIONAL ASSUMES NO LIABILITY FOR APPLICATIONS ASSISTANCE OR BUYER PRODUCT DESIGN. BUYERS ARE RESPONSIBLE FOR THEIR PRODUCTS AND APPLICATIONS USING NATIONAL COMPONENTS. PRIOR TO USING OR DISTRIBUTING ANY PRODUCTS THAT INCLUDE NATIONAL COMPONENTS, BUYERS SHOULD PROVIDE ADEQUATE DESIGN, TESTING AND OPERATING SAFEGUARDS.

EXCEPT AS PROVIDED IN NATIONAL'S TERMS AND CONDITIONS OF SALE FOR SUCH PRODUCTS, NATIONAL ASSUMES NO LIABILITY WHATSOEVER, AND NATIONAL DISCLAIMS ANY EXPRESS OR IMPLIED WARRANTY RELATING TO THE SALE AND/OR USE OF NATIONAL PRODUCTS INCLUDING LIABILITY OR WARRANTIES RELATING TO FITNESS FOR A PARTICULAR PURPOSE, MERCHANTABILITY, OR INFRINGEMENT OF ANY PATENT, COPYRIGHT OR OTHER INTELLECTUAL PROPERTY RIGHT.

LIFE SUPPORT POLICY

NATIONAL'S PRODUCTS ARE NOT AUTHORIZED FOR USE AS CRITICAL COMPONENTS IN LIFE SUPPORT DEVICES OR SYSTEMS WITHOUT THE EXPRESS PRIOR WRITTEN APPROVAL OF THE CHIEF EXECUTIVE OFFICER AND GENERAL COUNSEL OF NATIONAL SEMICONDUCTOR CORPORATION. As used herein:

Life support devices or systems are devices which (a) are intended for surgical implant into the body, or (b) support or sustain life and whose failure to perform when properly used in accordance with instructions for use provided in the labeling can be reasonably expected to result in a significant injury to the user. A critical component is any component in a life support device or system whose failure to perform can be reasonably expected to cause the failure of the life support device or system or to affect its safety or effectiveness.

National Semiconductor and the National Semiconductor logo are registered trademarks of National Semiconductor Corporation. All other brand or product names may be trademarks or registered trademarks of their respective holders.

Copyright© 2008 National Semiconductor Corporation

For the most current product information visit us at www.national.com



**National Semiconductor
Americas Technical
Support Center**
Email:
new.feedback@nsc.com
Tel: 1-800-272-9959

**National Semiconductor Europe
Technical Support Center**
Email: europe.support@nsc.com
German Tel: +49 (0) 180 5010 771
English Tel: +44 (0) 870 850 4288

**National Semiconductor Asia
Pacific Technical Support Center**
Email: ap.support@nsc.com

**National Semiconductor Japan
Technical Support Center**
Email: jpn.feedback@nsc.com